

# Accuride®

**MODELS 3832A, 3834A, 3837A**  
32mm Full Extension Drawer Slide  
With Optional Face Frame Bracketry

**Applications:** Use wherever a medium duty full extension slide is required. Not for lateral file drawer applications. ♦ Use for side mount only.

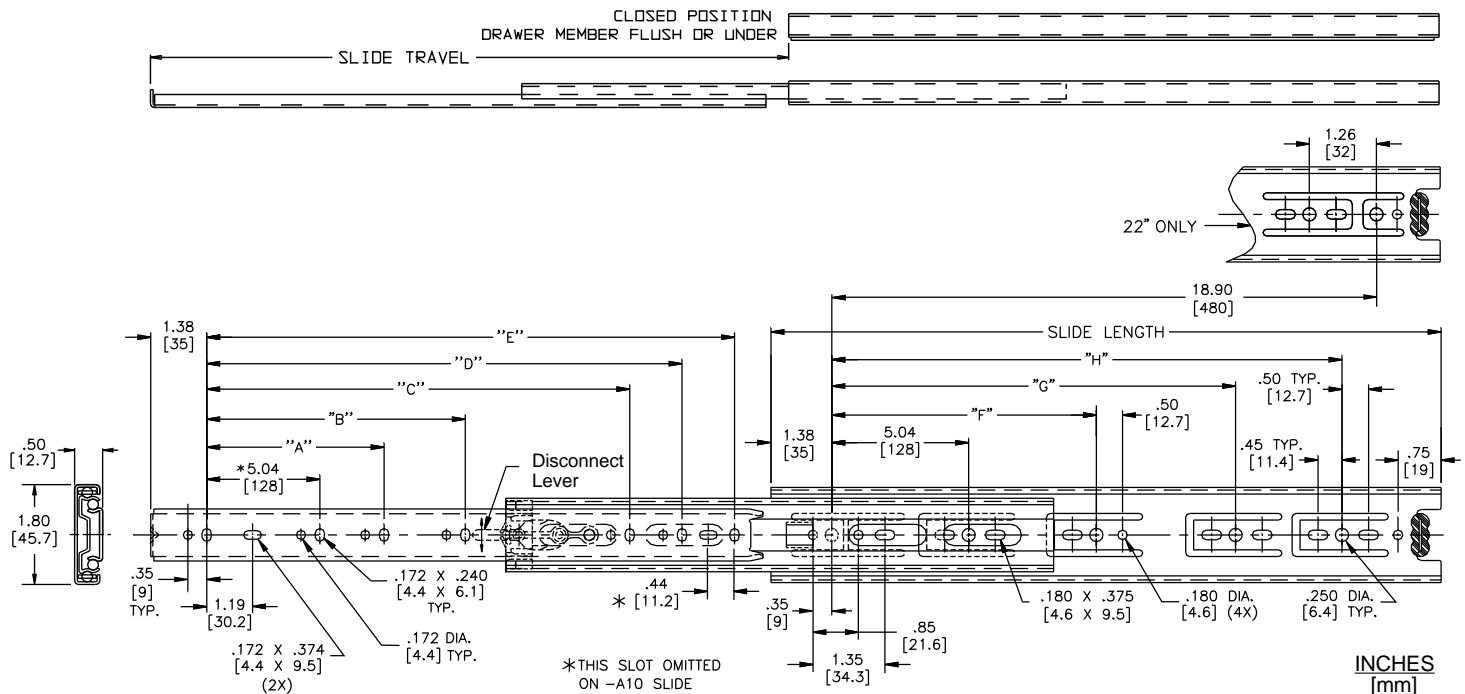

**Sidespace** .50" (+.062 -0.000)

**Length** Model 3832A & 3837A available in 10" - 28"  
Model 3834A available in 12" - 28" only

**Height** 1.80"

**Disconnect** Front, unhandled disconnect lever

**Hardware** Flat head 6mm Euro System screw or #8 pan head screw

**Mounting** Side; optional brackets for face frame or rear mounting

**Features** Positive stop; unhandled; cabinet member holes located in 32mm increments; hold-in detent; silenced in both open and closed positions

\* Load rating is based on a 18" slide on a 16" wide drawer cycled 50,000 times.

♦ A lateral file drawer is wider than it is deep.

Model	Load Rating*	Extension	Ball Bearings	Finish
3832A	100 Lb.	Full	Steel "EW" Finish Only Acetal Polymer Drawer Member	(C) Electro Zinc (CB) Black Zinc (EW) Epoxy White
3834A	90 Lb.	Full extension plus 1" over-travel		(C) Electro Zinc (CB) Black Zinc
3837A	100 Lb.	Full	Steel - Cabinet Member Acetal Polymer - Drawer Member	(C) Electro Zinc (CB) Black Zinc

Part Number	Length	Travel	A	B	C	D	E	F	G	H
-A10	9.84 [250]	10.00 [243]					7.55 [192.0]			
-A12	11.81 [300]	12.00 [305]					9.52 [242.0]	8.82 [224.0]		
-A14	13.78 [350]	14.00 [355]					11.49 [292.0]	8.82 [224.0]		
-A16	15.75 [400]	16.00 [406]			12.60 [320.0]		13.46 [342.0]	8.82 [224.0]	12.60 [320.0]	
-A17	16.73 [425]	17.00 [432]				13.59 [345.0]	14.45 [367.0]	8.82 [224.0]	12.60 [320.0]	
-A18	17.72 [450]	18.00 [457]			12.60 [320.0]		15.43 [392.0]	8.82 [224.0]	13.86 [352.0]	
-A20	19.69 [500]	20.00 [508]	8.82 [224.0]		12.60 [320.0]	16.38 [416.0]	17.40 [442.0]	8.82 [224.0]	16.38 [416.0]	
-A22	21.65 [550]	22.00 [559]	8.82 [224.0]		16.38 [416.0]		19.37 [492.0]	8.82 [224.0]	13.86 [352.0]	17.64 [448.1]
-A24	23.62 [600]	24.00 [610]	8.82 [224.0]		16.38 [416.0]		21.34 [542.0]	8.82 [224.0]	13.86 [352.0]	18.90 [480.1]
-A26	25.59 [650]	26.00 [660]	8.82 [224.0]		16.38 [416.0]	21.42 [544.0]	23.31 [592.0]	8.82 [224.0]	13.86 [352.0]	21.42 [544.1]
-A28	27.56 [700]	28.00 [711]	8.82 [224.0]	12.60 [320.0]	16.38 [416.0]	21.42 [544.0]	25.28 [642.0]	8.82 [224.0]	13.86 [352.0]	21.42 [544.1]

## MOUNTING INSTRUCTIONS

### Mounting Into Frameless Cabinets

1. Separate slide members by lifting up or pushing down the disconnect lever.
2. Install large cabinet members. See figure 1.
3. Check that both cabinet members are vertically and horizontally parallel. Make necessary adjustments.
4. Install drawer member through vertical slots. See figure 2.
5. Insert drawer member making sure ball bearing retainers are fully forward. Close drawer completely.
6. Adjust position and install two more screws in round holes.

### Ordering Procedure

Complete your slide order for Accuride models 3832A, 3834A, OR 3837A by specifying the following:

Total Required Slides \_\_\_\_\_ 100 Pair C 3832 -A16 D  
 Finish \_\_\_\_\_  
 Slide Model \_\_\_\_\_  
 Slide Length \_\_\_\_\_  
 Polybag Packaging - includes screws \_\_\_\_\_

### Packaging

**Distributor (D) Pack:** All lengths are packaged 10 pair/box. Polybag includes one pair of slides packed with screws.

**Bulk (P) Pack:** All lengths are packaged 10 pair/box. Slides and screws are ordered and packaged separately.

### Optional Face Frame Brackets

Accuride offers optional metal front and rear brackets. This bracketry is designed for use with 3800A series slides manufactured after 6/97. Slides manufactured prior to 7/97 do not include a cabinet member hole which allows the slide to properly engage the plastic lug on the rear bracket. Manufacture date can be verified by checking the date code located on the inside of the slide drawer (inner) member.

For face frame mounting, order kit P/N 4180-0322-XE. Zinc plated brackets are packaged together in a polybag. Order one kit per pair of slides. See figure 5.

Kit contains:

2 each front bracket P/N 4010-0516-CE  
 2 each rear bracket P/N 4080-0220-CE  
 1 each installation sheet

### Specifications

Slide members and ball retainers: Cold rolled steel  
 Ball bearings: Acetal polymer and carburized steel

**Note:** Specifications, materials, prices, terms and delivery are subject to change without notice.

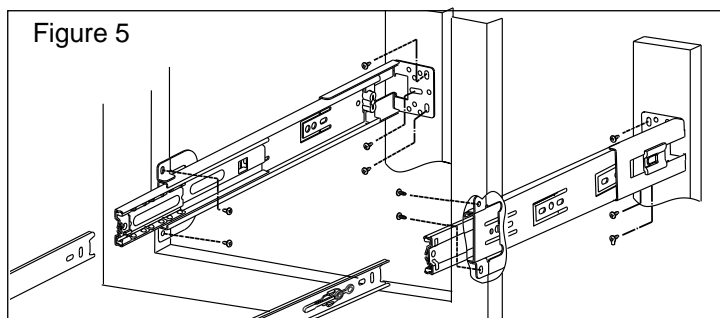
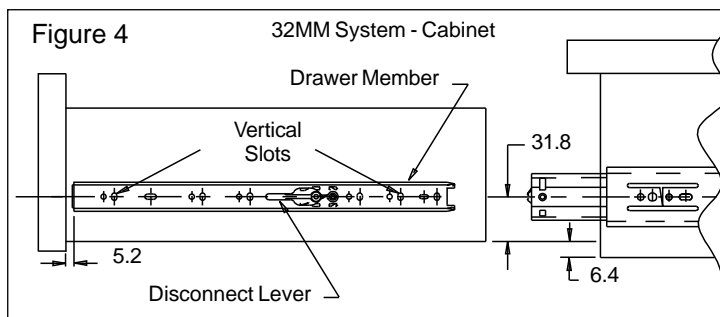
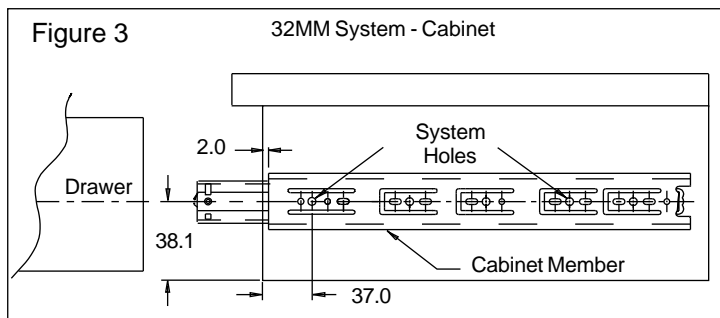
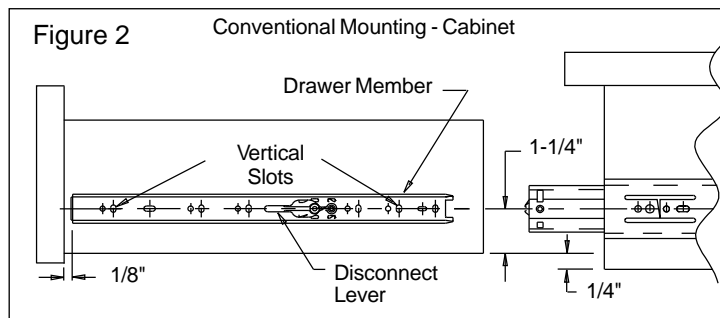
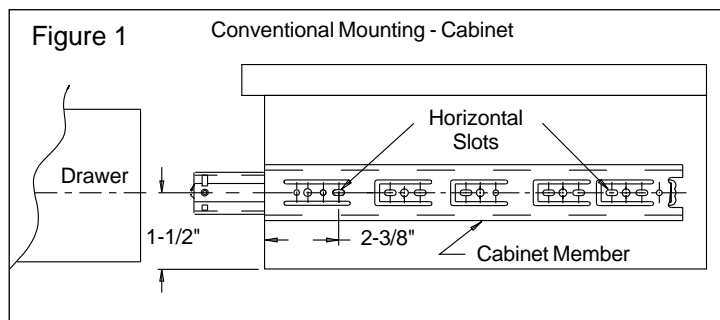

Authorized Distributor

**Accuride**  
 Headquarters and Main Plant

12311 Shoemaker Avenue Santa Fe Springs, CA 90670  
 TEL (562)903-0200 • FAX (562)903-0208  
 Manufacturing, Engineering, and Sales  
 United States • Germany • Japan • Mexico • United Kingdom  
 Copyright © 1998 Accuride International Inc.  
 Printed in U.S.A. 3700-9381(1057)9008-MK038-R4-0698