

User Manual

3800

3800

System Enclosure



IBUS™

109-40055-00 Rev. A

A **Maxwell** TECHNOLOGIES COMPANY

3800 System Enclosure User Manual, 095-20057-00-00 Rev. A.
Copyright ©1997 by I-Bus, a Division of Maxwell Laboratories,
Inc., printed and bound in the United States. All rights reserved. No
part of this manual may be reproduced in any form or by any
electronic or mechanical means, including information storage and
retrieval systems, without the written permission of I-Bus.

All trademarks are the property of their respective companies.

Customer Service

Mailing Address: I-Bus, Inc.
a Maxwell Technologies Company
P.O. Box 84239
San Diego, CA 92123

Telephone: (619) 974-8400
(800) 382-4229 (in the U.S.)

FAX: (619) 268-7863

E-Mail: infor@ibus.com

Visit our site at: <http://www.ibus.com>

Table of Contents

Chapter 1 Introduction

About this manual	1-2
Preparing the System	1-3
Features	1-6

Chapter 2 Power and Control Systems

Power Supply	2-1
Changing the AC Input Selection Switch	2-1
Connectors	2-1
Removing the Power Supply	2-3
Installing the Power Supply	2-3
Removing the Backplane/Motherboard	2-4
Installing the Backplane/Motherboard	2-4
Switches	2-5
Removing the Power Switch	2-5
Installing the Power Switch	2-6
Removing the Reset/LED Circuit Board	2-6
Installing the Reset/LED Circuit Board	2-7

Chapter 3 Peripheral Installation

Removing an Expansion Card	3-1
Installing an Expansion Card	3-2
Removing the 3.5 Inch Drive Bay	3-2
Installing the 3.5 Inch Drive Bay	3-3
Removing the 3.5 Inch Floppy Drive	3-3
Installing the 3.5 Inch Floppy Drive	3-3
Removing the Hard Drive	3-4
Installing the Hard Drive	3-4

Table of Contents

Removing the 5.25 Inch Drive	3-5
Installing the 5.25 Inch Drive	3-6

Chapter 4 Hardware

Removing the Chassis Access Cover	4-1
Replacing the Chassis Access Cover	4-1
Removing the Fan	4-1
Installing the Fan	4-2
Removing the Speaker	4-3
Installing the Speaker	4-3

Chapter 5 Specifications

Environmental Specifications	5-1
AC Input Specifications	5-1
Voltage Regulation Tolerances	5-2
Output Load Capacity	5-2
Chassis Dimensions	5-2

Appendix 1 Technical Reference

ISA Bus Signal Termination Definitions	A1-1
PCI/ISA Connector Pin Assignments	A1-3

Appendix 2 Glossary of Terms

Appendix 3 Illustrations

3800 System Enclosure	A3-2
8-Slot ISA Passive Backplane	A3-3
18-Slot PCI/ISA Passive Backplane	A3-4
3800 System Interconnect Diagram	A3-5

Table of Contents

Index

List of Figures

Figure 1-1	3800 System Enclosure	1-5
Figure 2-1	3800 Chassis Position for Hardware Removal and Installation	2-1
Figure 2-2	Rear View of Power Switch	2-10
Figure 3-1	3.5 and 5.25 Inch Drive Bays	3-2
Figure 3-2	5.25 Inch Drive Bay	3-5

List of Tables

Table 2-1	Backplane/Motherboard Connectors	2-2
Table 2-2	Disk Drive Power Connector Voltages	2-3
Table 5-1	Environmental Specifications	5-1
Table 5-2	AC Input Specifications	5-1
Table 5-3	Input Frequency Range	5-1
Table 5-4	200W P/S Voltage Regulation Tolerances	5-2
Table 5-5	200W P/S Output Load Capacity	5-2
Table A1-1	ISA Bus Signal Termination Definitions	A1-1
Table A1-2	PCI Connector Pin Assignments	A1-3

WARNING!

Use caution when replacing the battery on any CPU board whether or not it is installed in a chassis. There is a danger of explosion if the battery is incorrectly replaced.

Replace the battery only with the same or the equivalent type recommended by the manufacturer. Dispose of used batteries according to the manufacturer's instructions.

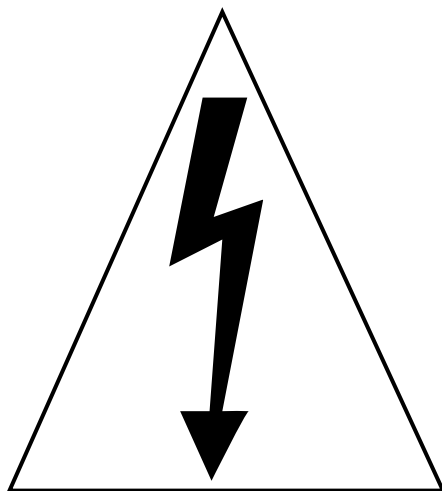

WARNING!

Any repair or maintenance that requires removal of the top cover must be made by a qualified technician.

LIMITED WARRANTY

I-Bus warrants this product to be free of defects in material and workmanship for an initial period of two (2) years from date of delivery to the original purchaser from I-Bus.

During this period, I-Bus will, at its option, repair or replace this product at no additional charge to the purchaser, except as set forth in this warranty agreement.

I-Bus will, at its option, repair or replace this product at no additional charge to the purchaser, if the defect is related to the I-Bus manufactured product, such as power supply, backplanes, other chassis components, or CPUs. I-Bus is not liable for any defects in material or workmanship of any peripherals, products or parts which I-Bus does not design or manufacture. However, I-Bus will honor the original manufacturer's warranty for these products.

I-Bus will analyze the defective component and the customer will be charged in the following instances:

- No problem found: \$75 (U.S. dollars).
- Damage: parts and labor at \$75 per hour with a \$100 minimum charge (U.S. dollars). Receipt of damaged goods voids the I-Bus warranty.

Repair parts and replacement products will be furnished on an exchange basis and will be either new or reconditioned. All replacement parts and products shall become the property of I-Bus, if such parts or products are provided under this warranty agreement. In the event a defect is not related to the I-Bus manufactured product, I-Bus shall repair or replace the defective parts at purchaser's cost and deliver the defective parts to the purchaser.

This Limited Warranty shall not apply if the product has been misused, carelessly handled, defaced, modified or altered, or if unauthorized repairs have been attempted by others.

The above warranty is the only warranty authorized by I-Bus and is in lieu of any implied warranties, including implied warranty of merchantability and fitness for a particular purpose.

In no event will I-Bus be liable for any such damage as lost business, lost profits, lost savings, downtime or delay, labor, repair or material cost, injury to person or property or any similar or dissimilar consequential loss or damage incurred by purchaser, even if I-Bus has been advised of the possibility of such losses or damages.

In order to obtain warranty service, the product must be delivered to the I-Bus facility, or to an authorized I-Bus service representative, with all included parts and accessories as originally shipped, along with proof of purchase and a Returned Merchandise Authorization (RMA) number. **The RMA number is obtained, in advance, from I-Bus Customer Service Department and is valid for 30 days. The RMA number must be clearly marked on the exterior of the original shipping container or equivalent. Purchaser will be responsible and liable for any missing or damaged parts. Purchaser agrees to pay shipping charges one way, and to either insure the product or assume the liability for loss or damage during transit.** Ship to:

I-Bus
ATTENTION: RMA REPAIR DEPT.
RMA #####
9174 Sky Park Court
San Diego, CA 92123

I-Bus may issue, at its own discretion, an advanced replacement (AR) on a product if it fails within fifteen (15) days from the date of delivery from I-Bus.

Chapter 1 Introduction

Welcome to the I-Bus family of system enclosures. In this manual you will find the information you need to set up and maintain your 3800 System Enclosure.

The *3800 System Enclosure* contains a fan-cooled, 8-slot ISA passive backplane, an 8-slot PCI/ISA dual bus passive backplane, or a Baby AT motherboard. It is equipped with a 200W output, switching 115/230VAC power supply and is offered in a tower configuration.

This chapter is divided into three sections:

- *About this manual*

explains how this manual is laid out and what you can expect to find in it.

- *Preparing the System*

defines the items included with your system and describes the procedure for unpacking and setting up your 3800 System Enclosure for operation.

- *Features*

provides a brief overview of the major components of the 3800, accompanied by an illustration showing all of its features.

About this manual

This manual contains five chapters that pertain specifically to your 3800 System Enclosure. The three appendices contain technical reference material, a glossary of terms, and illustrations, followed by an index.

- ***Chapter 1 Introduction***

introduces you to this manual and to your 3800. It contains an illustration of the system and a brief description of its features.

- ***Chapter 2 Power and Control Systems***

discusses the chassis access cover, power supply, backplane/motherboard, and power and reset switches, and includes instructions on removing and installing each.

- ***Chapter 3 Peripheral Installation***

describes the removal and installation of expansion cards, drive bays, and drives.

- ***Chapter 4 Hardware***

describes the removal and installation of the fan, fan bracket, and speaker.

- ***Chapter 5 Specifications***

provides the environmental specifications and technical data of your system. It also provides voltage regulation tolerances and output load capacities of the power supplies.

- ***Appendix 1 Technical Reference***

provides the bus termination definitions for the backplanes and motherboards.

- ***Appendix 2 Glossary of Terms***

contains definitions of terms used in this manual as well as terms that refer to items discussed.

Chapter 1 Introduction

- *Appendix 3 Illustrations*

contains an illustration of the 3800. It also contains illustrations of the 8-slot ISA backplane, the 8-slot PCI/ISA backplane, and the system interconnect diagram.

- *Index*

provides easy access to page numbers of items discussed in this manual.

Preparing the System

- *Unpacking your 3800 System Enclosure*

- Unpack your system at a static-free workstation while observing proper Electrostatic Discharge (ESD) practices. I-Bus reserves the right to refuse warranty service on units not properly packaged to protect against ESD damage.
- Be sure the power supply is set at the appropriate voltage.

CAUTION!

Components in this chassis are sensitive to damage from Electrostatic Discharge (ESD). Handling of the components should ONLY be done by a properly trained technician in an approved ESD work area!

Packaged with your 3800 are:

- a *3800 System Enclosure User Manual*
- a power cord

If any of the items have been damaged in shipping, notify the transit company and initiate an insurance claim. If any items are missing, contact I-Bus. Refer to the Limited Warranty in the back of this manual for further instructions.

Setting up your 3800 System Enclosure

- *Setting up your 3800 System Enclosure*
 - Ensure that the power supply is set to the correct input voltage PRIOR to plugging the power cord into a grounded outlet.
 - Do not block the air vents or place the unit too close to a wall.

Chapter 1 Introduction

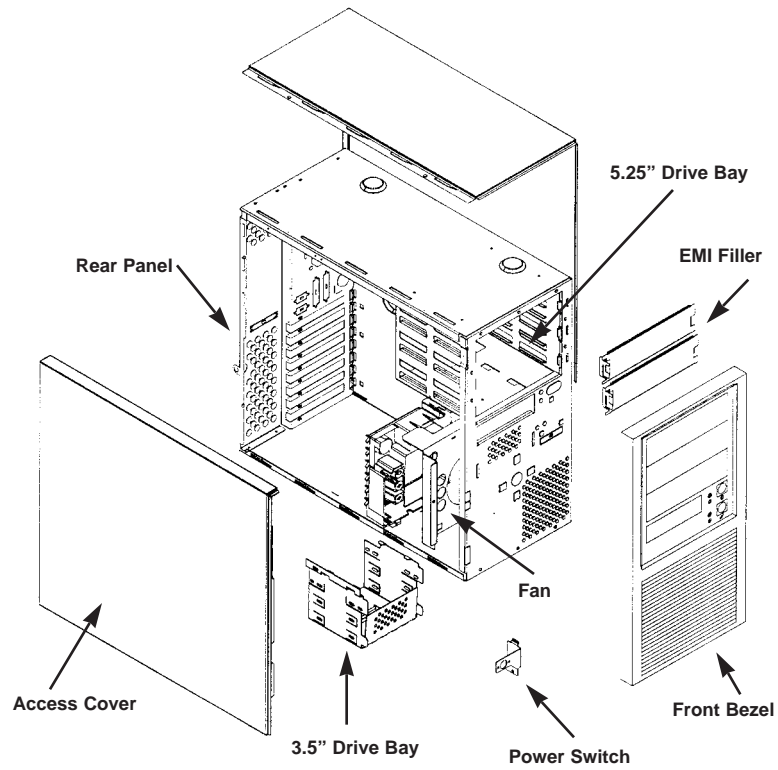

Figure 1-1: 3800 System Enclosure

Features

Features

- *Power*

The 3800 is equipped with a 200W switching 115/230VAC power supply.

- *Cooling*

Fans in the chassis and power supply distribute cooling air throughout the enclosure.

- *Drives*

The drive bay, with front panel access, can accommodate up to three half-height (5" or 3fi") drives. An additional drive bay can hold three half height 3fi" drives, one of which is externally available.

- *Backplane/Motherboard*

The 3800 is equipped with an ISA 8-slot passive backplane, a PCI/ISA dual-bus passive backplane, or a motherboard. The PCI/ISA backplane contains four ISA slots, two PCI slots, one shared ISA and PCI slot (only one of which can be used at a time), and one slot for the CPU board.

- *Front Controls and Indicators*

The reset switch, power switch, power on LED, and hard drive LED are mounted on the front of the chassis.

Chapter 2 Power and Control Systems

This chapter describes the chassis access cover, power supply, motherboard, backplane, and control switches, and discusses how to remove and install each.

Note: The following instructions on removal and installation of the above hardware are explained from a perspective in which the chassis is positioned horizontally, with the front panel facing the technician. Thus, for purposes of explanation, “the right side of the chassis,” for example, in the following sections actually refers to what would be its top bezel when in operation. See “Figure 2-1: 3800 Chassis Position for Hardware Removal and Installation,” below, for clarification.

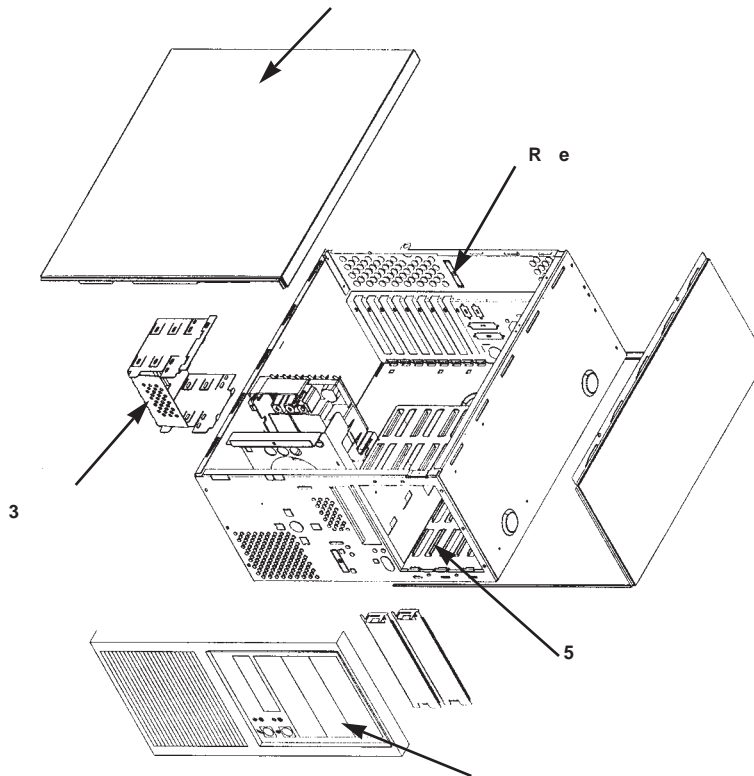

Figure 2-1: 3800 Chassis Position for Hardware Removal and Installation

Power Supply

Power Supply

The PS/2 style power supply measures 6.0"H x 3.4"W x 5.5"D. The power supply constantly monitors the 115/230VAC input and asserts an active power good signal.

- **Changing the AC Input Selection Switch**

The input voltage may be set at 115VAC or 230VAC. To change the input voltage:

- turn the system OFF,
- toggle the switch on the rear of the power supply to 115V or 230V and apply the corresponding voltage.

- **Connectors**

Two types of connectors extend from the power supply: backplane/motherboard power connectors, and disk drive power connectors. The disk drive power connectors are identical and are not labeled.

The following connector voltages apply to the backplane/motherboard connectors. The “J” numbers refer to the backplane pinouts. The “P” numbers refer to the motherboard pinouts. The value of “x” and “y” will vary depending on which backplane or motherboard is installed in your system.

J(x) / P(x)		J(y) / P(y)	
Pin1	P.G.	Pin1	GND
Pin2	+5V	Pin2	GND
Pin3	+12V	Pin3	-5V
Pin4	-12V	Pin4	+5V
Pin5	GND	Pin5	+5V
Pin6	GND	Pin6	+5V

Table 2-1: Backplane/Motherboard Connectors

Chapter 2 Power and Control Systems

The following connector voltages apply to all disk drive power connectors.

Disk Drive Power Connector Voltages	
Pin 1	+12V
Pin 2	GND
Pin 3	GND
Pin 4	+5V

Table 2-2: Disk Drive Power Connector Voltages

- *Removing the Power Supply*

CAUTION!

Only a qualified technician should remove the power supply.

Before Proceeding:

- Turn the power OFF and unplug the power cord.
- Save all original hardware.

To remove the power supply:

1. Remove the chassis access cover as described on page 4-1.
2. Disconnect all cables from the drives and cut any cable tie that is holding down the power supply's wiring.
3. Remove the 3.5" drive bay as described on page 3-2.
4. Disconnect the power supply from the power switch.
5. Remove the power supply's four mounting screws.
6. Slide the power supply towards the front of the chassis. Tilt the back end of the power supply upwards and lift the unit out.

- *Installing the Power Supply*

1. Make sure the 3.5" drive bay is removed in order to access the power switch.
2. Insert the power supply in the rear, right-hand corner of the chassis.

Installing the Power Supply

3. Slide the back of the power supply under the tabs on the bottom of the chassis.
 4. Slide the power supply toward the back of the chassis. When inserted properly, the power supply's INPUT connector will be exposed through the rear chassis wall.
 5. Attach the power switch to the wiring harness.
 6. Insert the power supply's four mounting screws.
- ***Removing the Backplane/Motherboard***

CAUTION!

Only a qualified technician should remove the backplane or motherboard.

CAUTION!

Components on the backplane and motherboard are sensitive to damage from Electrostatic Discharge (ESD). Handling of this board should ONLY be done by a properly trained technician in an approved ESD work area!

1. Remove the chassis access cover as described on page 4-1.
 2. Disconnect any cables attached to the backplane/motherboard.
 3. Remove the expansion cards from the backplane/motherboard as described on page 3-1.
 4. Remove the backplane's/motherboard's mounting screws. Lift the backplane/motherboard out of the chassis.
- ***Installing the Backplane/Motherboard***
 1. Place the backplane/motherboard in the chassis, positioning it so that its power connectors are on the side closest to the power supply. Align the mounting holes on the backplane/motherboard with those on the chassis.
 2. Insert the mounting screws and tighten them.
 3. Reconnect the power connectors.

Chapter 2 Power and Control Systems

4. Install the expansion card(s) firmly into the backplane/motherboard as described on page 3-2.
5. Attach all cables and connectors to the expansion cards.

CAUTION!

Over-tightening the screws may damage the backplane or motherboard

Switches

The 3800 has one power switch and one reset switch, both located on the front control panel in the center of the chassis.

- **Removing the Power Switch**

Before proceeding:

- Turn the power OFF and unplug the power cord.
- Save all original hardware.

To remove the power switch:

1. Remove the chassis access cover as explained on page 4-1.
2. Remove the 3.5" drive bay as explained on page 3-2.
3. Remove the power supply connectors from the power switch.
4. Remove the power switch's mounting screw from the chassis.
5. Lift the power switch out of the chassis.

Installing the Power Switch

- *Installing the Power Switch*

1. Make sure the 3.5" drive bay is removed.
2. Attach the power switch to the chassis with the mounting screw.
3. Attach the power supply connectors to the power switch using the diagram below.

Top of Chassis
Light Colors (white,

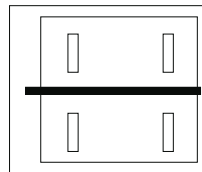

Dark Colors (black,

Figure 2-2: Power Switch Connectors

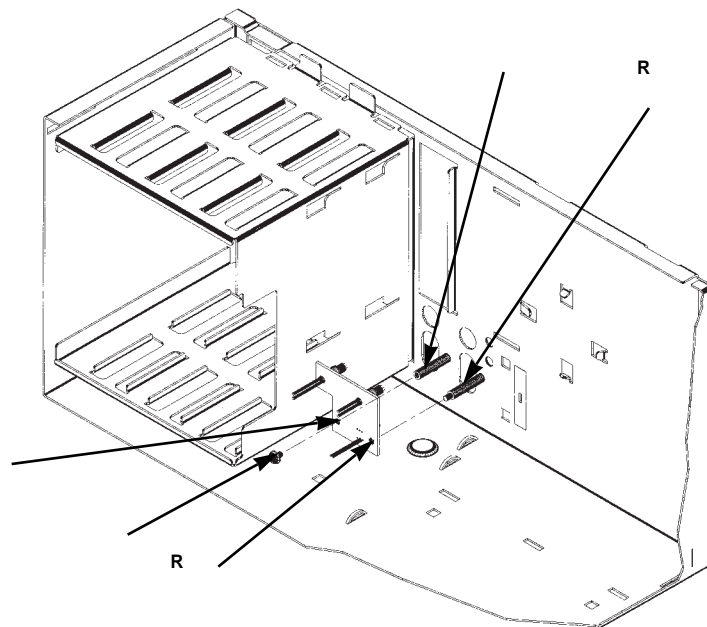

Figure 2-3: Reset/LED Circuit Board

Chapter 2 Power and Control Systems

- *Removing the Reset/LED Circuit Board (refer to Figure 2-3)*

Before proceeding:

- Turn the power OFF and unplug the power cord.
- Save all original hardware.

To remove Reset/LED Circuit Board:

1. Remove the chassis access cover as described on page 4-1.
2. Remove the 3.5" drive bay as described on page 3-2.
3. Remove the power switch as described on page 2-5. There is no need to disconnect the power wiring.
4. Cut the cable tie surrounding the Reset/LED circuit board's backplane/motherboard connectors.
5. Remove the mounting screw attached to the Reset/LED circuit board's left mounting post.
6. Pull the Reset/LED circuit board off of the right mounting post by pulling it towards the back of the chassis.

- *Installing the Reset/LED Circuit Board*

1. Make sure the 3.5" drive bay and the power switch are removed.
2. Place the Reset/LED circuit board into position in the chassis by sliding its right mounting hole onto the chassis's right mounting post.
3. Attach the mounting screw to the left mounting post.
4. Secure the Reset/LED circuit board and fan power connectors using cable tie.

Chapter 3 Peripheral Installation

This chapter describes the installation and removal of the expansion cards, drive bays, and drives in your 3800 system enclosure.

Note: The following instructions on removal and installation of the above peripherals are explained from a perspective in which the chassis is positioned horizontally, with the front panel facing the technician. Thus, for purposes of explanation, “the right side of the chassis,” for example, in the following sections actually refers to what would be its top bezel when in operation. See “Figure 2-1: 3800 Chassis Position for Hardware Removal and Installation,” p. 2-1, for clarification.

CAUTION!

Electrostatic Discharge (ESD) may damage memory chips, programmed devices and other electrical components. ESD can be prevented by wearing a wrist strap attached to a ground post on a static mat.

- ***Removing an Expansion Card***

Before Proceeding:

- Turn the power OFF and unplug the power cord.
- Save all original hardware.

To remove an expansion card

1. Remove the chassis access cover as described on page 4-1.
2. Disconnect any cables and connectors from the expansion card.
3. Take out the mounting screw.
4. Pull up on the expansion card and lift it out of the back-plane/motherboard.

Installing an Expansion Card

- *Installing an Expansion Card*

1. Place the expansion card into its slot in the backplane/motherboard and push it down to set in place.
2. Attach the mounting screw to the chassis.

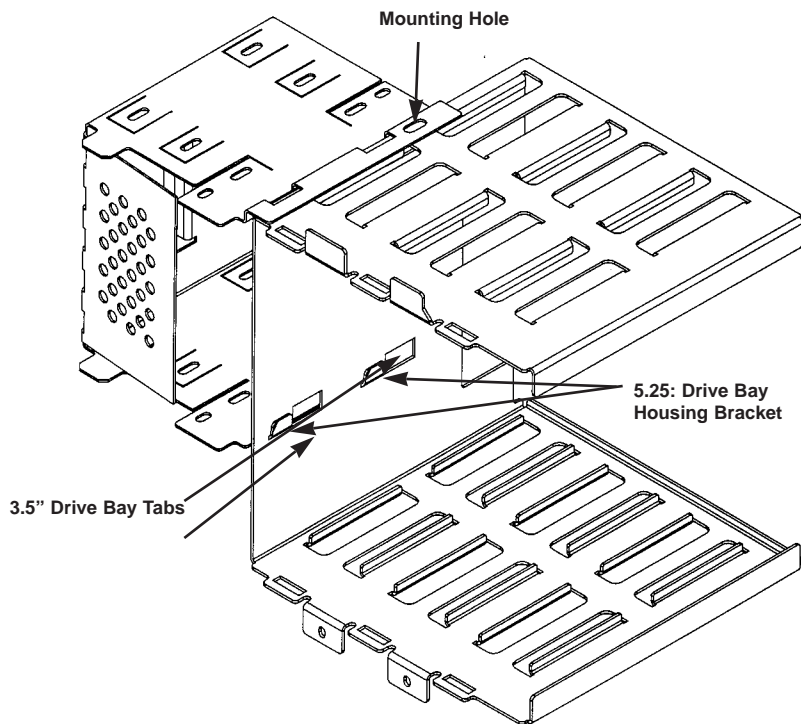

Figure 3-1: 3.5 and 5.25 Inch Drive Bays

- *Removing the 3.5 Inch Drive Bay (refer to figure 3-1):*

Before Proceeding:

- Turn the power OFF and unplug the power cord.
- Save all original hardware.

Chapter 3 Peripheral Installation

To remove the 3.5 inch drive bay

1. Remove the chassis access cover as described on p. 4-1.
2. Disconnect all cables from all drives in the drive bay.
3. Remove the drive bay's two mounting screws (one on the 5.25" drive bay, one on the mounting bracket).
4. Slide the drive bay toward the back of the chassis and lift it out.

- ***Installing the 3.5 Inch Drive Bay (refer to figure 3-1):***

1. Slide the drive bay into place inside the chassis, making sure to fit its two tabs into place inside the slots on the housing bracket of the 5.25" drive bay.
2. Attach the two mounting screws.

- ***Removing the 3.5 Inch Floppy Drive***

Before Proceeding:

1. Turn the power OFF and unplug the power cord.
2. Save all original hardware.

To remove the 3.5 inch floppy drive:

1. Remove the 3.5" drive bay as described on page 3-2.
2. Remove the four mounting screws attaching the floppy drive to the drive bay.
3. Slide the floppy drive out of the drive bay.

- ***Installing the 3.5 Inch Floppy Drive***

1. Slide the floppy drive into the front of the drive bay.
2. Mount the floppy drive so that it is flush with the front bezel. Some adjustment may be required depending on the particular floppy drive used.
3. Attach the floppy drive's four mounting screws to the drive bay.

Removing the Hard Drive

- *Removing the Hard Drive*

1. Remove the 3.5" drive bay as described on page 3-2.
2. Remove the four mounting screws attaching the hard drive to the drive bay.
3. Slide the hard drive out of the drive bay.

- *Installing the Hard Drive*

1. Slide the hard drive into the drive bay.
2. Attach the hard drive's four mounting screws.

Chapter 3 Peripheral Installation

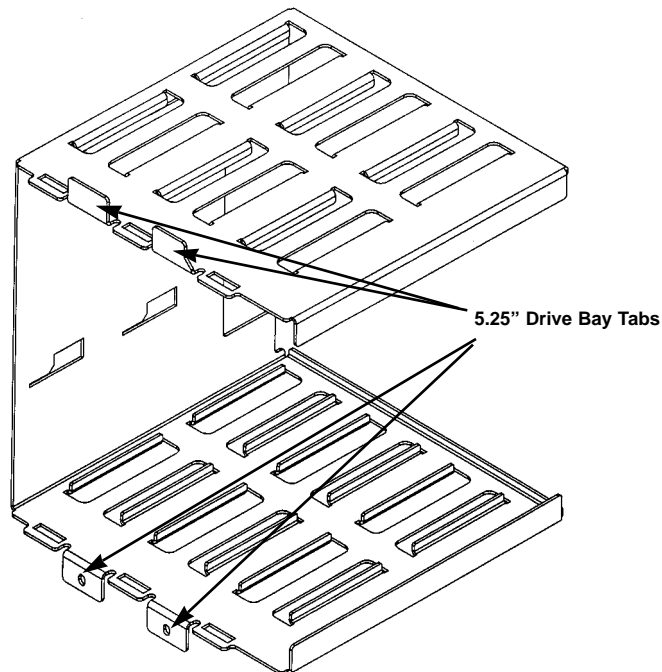

Figure 3-2: 5.25 Inch Drive Bay

- **Removing the 5.25 Inch Drive (refer to Figure 3-2):**

Before Proceeding:

1. Turn the power OFF and unplug the power cord.
2. Save all original hardware.

To remove the 5.25 inch drive

1. Remove the chassis access cover as described on page 4-1.
2. Remove the chassis's front bezel by taking out the mounting screw and then pulling the bezel upward and outward. The cover should lift out of place.
3. Disconnect all cables from the drives in the drive bay.
4. Push in the tabs located on the top and bottom of the drive's front side and slide the drive out of the drive bay.

Installing the 5.25 Inch Drive

- ***Installing the 5.25 Inch Drive (refer to Figure 3-2):***
 1. Mount the drive slides on the drive. The “B” slide goes on the top of the drive and the “A” slide goes on the bottom. The letter should be right-side-up when read while facing the drive from its front.
 2. Slide the drive into the bay as far as it will go. When it is impeded by the tabs located on the top and bottom of the drive’s front side, press down on the tabs and slide the drive further into the bay.
 3. Verify that the drive is locked into place.

Chapter 4 Hardware

This chapter discusses the removal and installation of the chassis access cover, fan, and fan bracket.

Note: The following instructions on removal and installation of the above hardware are explained from a perspective in which the chassis is positioned horizontally, with the front panel facing the technician. Thus, for purposes of explanation, “the right side of the chassis,” for example, in the following sections actually refers to what would be its top bezel when in operation. See “Figure 2-1: 3800 Chassis Position for Hardware Removal and Installation,” p. 2-1, for clarification.

- *Removing the Chassis Access Cover*

Before Proceeding:

- Turn the power OFF and unplug the power cord.
- Save all original hardware.

To remove the chassis access cover:

1. Remove the chassis access cover’s two mounting screws.
2. Slide the cover toward the rear of the chassis approximately one inch and lift the cover up.

- *Replacing the Chassis Access Cover*

1. Position the access cover on the chassis and slide it into place.
2. Attach the two mounting screws.

Fan

The fan provides forced air to cool the expansion cards.

Removing the Fan Housing

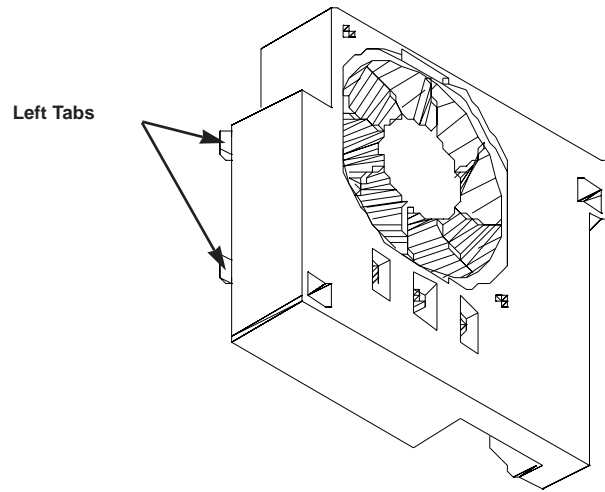

Figure 4-1: Fan Housing

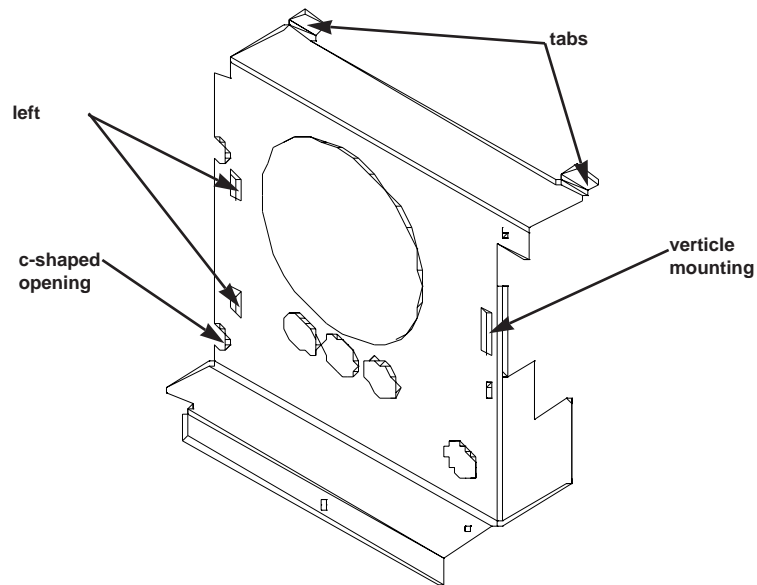

Figure 4-2: Fan Bracket

Chapter 4 Hardware

- *Removing the Fan Housing (refer to figure 4-1 and figure 4-2):*

Before proceeding:

- Turn the power OFF and unplug the power cord.
- Save all original hardware.

To remove the fan housing:

1. Remove the chassis access cover as described on page 4-1.
2. Disconnect the fan power connector.
3. Push the fan housing's right tab (which is inserted into the fan bracket's mounting slot) toward the rear of the chassis. Then, push the housing as far as possible toward the rear of the chassis.
4. Slide the fan housing toward the right and then push it toward the rear of the chassis, making sure that its two left tabs slide out of the fan bracket's left mounting slots.
5. Lift the fan housing out of the chassis.

- *Installing the Fan Housing (refer to figure 4-1 and figure 4-2):*

1. Slide the fan housing's two left tabs into the fan bracket's left mounting slots. Push the housing towards the chassis's front bezel. Slide its right tab into the fan bracket's vertical mounting slot and push it towards the chassis's front bezel.
2. Verify that the fan housing is locked into place.
3. Connect the fan power connector.

- *Removing the Fan Bracket (refer to figure 4-2):*

Before proceeding:

- Turn the power OFF and unplug the power cord.
- Save all original hardware.

Removing the Speaker

To remove the fan bracket:

1. Remove the fan housing as described on p. 4-3.
2. Remove the fan bracket's mounting screw.
3. Tilt the top of the fan bracket toward the back of the chassis and unhook its tabs from the slots in the bottom of the chassis.
4. Lift the fan bracket out of the chassis.

• **Installing the Fan Bracket (refer to figure 4-2):**

1. Tilt the top of the fan bracket toward the rear of the chassis. Slide the fan bracket's tabs into the slots in the bottom of the chassis.
2. Route the speaker cables through the fan bracket's bottom left c-shaped opening.
2. Attach the fan bracket's mounting screw.

• **Removing the Speaker**

Before proceeding:

- Turn the power OFF and unplug the power cord.
- Save all original hardware.

To remove the speaker

1. Remove the chassis access cover as described on p. 4-1.
2. Remove the fan housing and the fan bracket as described on p. 4-3.
3. Disconnect the speaker connector from the backplane/motherboard.
4. Pull the speaker toward the rear of the chassis and out from under its mounting tabs. *Some force may be necessary.*

Chapter 4 Hardware

- *Installing the Speaker*
 1. Make sure the fan and the fan bracket are removed.
 2. Place the speaker over the straight mounting tab.
 2. Slide the speaker under the three remaining (i.e., bent) mounting tabs.
 3. Attach the speaker connector to the backplane/motherboard.

Chapter 5 Specifications

Environmental Specifications

Environmental	Operating	Non-operating
Temperature:	0° to 50° C	-40° to 65° C
Humidity:	5 to 95% @ 40° C non-condensing	5 to 95% @ 40° C non-condensing
Shock:	3.5G @ 10ms duration	10G @ 10ms duration
Vibration:	.25G @ 5-100Hz	3.5G @ 5-100Hz

Table 5-1: Environmental Specifications

AC Input Specifications

Parameter	Minimum	Nominal	Maximum	Units
V-in Range (115V)	90	115	132	V-rms
V-in Range (120V)	180	230	264	V-rms

Table 5-2: AC Input Specifications

Input	Frequency Range
115VAC	47 Hz to 63 Hz
230VAC	47 Hz to 53 Hz

Table 5-3: Input Frequency Range

Voltage Regulation Tolerances

Voltage Regulation Tolerances

Output	Min. V	Max. V	Load Regulation	Ripple P-P	Noise
+ 5V	+4.85	+5.15	±5%	50mv	100mv
+ 12V	+11.40	+12.60	±5%	100mv	100mv
- 5V	-4.75	-5.50	±10%	50mv	150mv
- 12V	-11.40	-13.20	±10%	100mv	150mv

Table 5-4: 200W Power Supply Voltage Regulation Tolerances

Output Load Capacity

Output	Minimum	Maximum
+5V	5.0A	20.0A
+12V	1.0A	8.0A
-5V	0A	0.3A
-12V	0A	0.3A

Table 5-5: 200W Power Supply Output Load Capacity

Chassis Dimensions

(Dimensions include bezel)

Tower 16.9" deep x 15.74" high x 8.3" wide

Appendix 1 Technical Reference

- *ISA Bus Signal Termination Definitions*

Pin #	Signal Name	Direct.	Pin #	Signal Name	Direct.
A1	-IOCHECK	I	B1	GND	
A2	SD7	I/O	B2	RSTDRV	O
A3	SD6	I/O	B3	+5 VDC	
A4	SD5	I/O	B4	IRQ9	I
A5	SD4	I/O	B5	-5 VDC	
A6	SD3	I/O	B6	DRQ2	I
A7	SD2	I/O	B7	-12 VDC	
A8	SD1	I/O	B8	-0WS	I
A9	SD0	I/O	B9	+12 VDC	
A10	-IOCHRDY	I	B10	GND	
A11	AEN	O	B11	-SMEMW	O
A12	SA19	O	B12	-SMEMR	O
A13	SA18	O	B13	-IOW	O
A14	SA17	O	B14	-IOR	O
A15	SA16	O	B15	-DACK3	O
A16	SA15	O	B16	DRQ3	I
A17	SA14	O	B17	-DACK1	O
A18	SA13	O	B18	DRQ1	I
A19	SA12	O	B19	-RFSH	O
A20	SA11	O	B20	CLK	O
A21	SA10	O	B21	IRQ7	I
A22	SA9	O	B22	IRQ6	I
A23	SA8	O	B23	IRQ5	I
A24	SA7	O	B24	IRQ4	I
A25	SA6	O	B25	IRQ3	I

Table A1-1: ISA Bus Signal Termination Definitions (continued on next

Bus Signal Termination Definitions

Pin #	Signal Name	Direct.	Pin #	Signal Name	Direct.
A26	SA5	O	B26	-DACK2	O
A27	SA4	O	B27	T/C	O
A28	SA3	O	B28	BALE	O
A29	SA2	O	B29	+5 VDC	
A30	SA1	O	B30	OSC	O
A31	SA0	O	B31	GND	
C1	SBHE	O	D1	-MEMCS16	I
C2	LA23	I/O	D2	-IOCS16	O
C3	LA22	I/O	D3	IRQ10	I
C4	LA21	I/O	D4	IRQ11	I
C5	LA20	I/O	D5	IRQ12	I
C6	LA19	I/O	D6	IRQ15	I
C7	LA18	I/O	D7	IRQ14	I
C8	LA17	I/O	D8	-DACK0	O
C9	-MEMR	O	D9	DRQ0	I
C10	-MEMW	O	D10	-DACK5	O
C11	SD08	I/O	D11	DRQ5	I
C12	SD09	I/O	D12	-DACK6	O
C13	SD10	I/O	D13	DRQ6	I
C14	SD11	I/O	D14	-DACK7	O
C15	SD12	I/O	D15	DRQ7	I
C16	SD13	I/O	D16	+5 VDC	N/A
C17	SD14	I/O	D17	-MASTER	I
C18	SD15	I/O	D18	GND	

page)

Table A1-1: ISA Bus Signal Termination Definitions (continued)

An "I" indicates the signal is an input to the system board from the bus, and an "O" signifies

Appendix 1 Technical Reference

an output from the system board to the bus.

Pin#	Assign.	Pin#	Assign.	Pin#	Assign.	Pin#	Assign.
A01	TRST#	A32	AD16	B01	-12V	B32	AD17
A02	+12V	A33	+3.3V	B02	TCK	B33	C/BE2#
A03	TMS	A34	FRAME#	B03	GND	B34	GND
A04	TDI	A35	GND	B04	TDO	B35	IRDY#
A05	+5V	A36	TRDY#	B05	+5V	B36	+3.3V
A06	INTA#	A37	GND	B06	+5V	B37	DEVSEL#
A07	INTC#	A38	STOP#	B07	INTB#	B38	GND
A08	+5V	A39	+3.3V	B08	INTD#	B39	LOCK#
A09	CLKC	A40	SDONE	B09	REQ3#	B40	PERR#
A10	+5V(I/O)	A41	SB0#	B10	REQ1#1	B41	+3.3V
A11	CLKD	A42	GND	B11	GNT3#	B42	SERR#
A12	GND	A43	PAR	B12	GND	B43	+3.3V
A13	GND	A44	AD15	B13	GND	B44	C/BE1#
A14	GNT1#	A45	+3.3V	B14	CLKA	B45	AD14
A15	RST#	A46	AD13	B15	GND	B46	GND
A16	+5V(I/O)	A47	AD11	B16	CLKB	B47	AD12
A17	GNT0#	A48	GND	B17	GND	B48	AD10
A18	GND	A49	AD09	B18	REQ0#	B49	GND
A19	REQ2#	A50	KEY	B19	+5V (I/O)	B50	KEY
A20	AD30	A51	KEY	B20	AD31	B51	KEY
A21	+3.3V	A52	C/BE0#	B21	AD29	B52	AD08
A22	AD28	A53	+3.3V	B22	GND	B53	AD07
A23	AD26	A54	AD06	B23	AD27	B54	+3.3V
A24	GND	A55	AD04	B24	AD25	B55	AD05
A25	AD24	A56	GND	B25	+3.3V	B56	AD03
A26	GNT2#	A57	AD02	B26	C/BE3#	B57	GND
A27	+3.3V	A58	AD00	B27	AD23	B58	AD01
A28	AD22	A59	+5V(I/O)	B28	GND	B59	+5V (I/O)
A29	AD20	A60	REQ64#	B29	AD21	B60	ACK64#
A30	GND	A61	+5V	B30	AD19	B61	+5V
A31	AD18	A62	+5V	B31	+3.3V	B62	+5V

- *PCI connector pin assignments*

Table A1-2: PCI Connector Pin Assignments

Appendix 2 Glossary of Terms

B

backplane: A device containing slots, or sockets, for plugging in boards or cables.

bidirectional parallel port: An eight-bit port that can be used for an input as well as an output device.

bus: One or more electrical conductors that transmit power or binary data to the various sections of a computer or any common pathway between hardware devices. A computer bus connects the CPU to its main memory and the memory banks that reside on the control units of the peripheral devices. It is made up of two parts. Addresses are sent over the address bus to signal a memory location, and the data is transferred over the data bus to that location.

C

card cage: A cabinet or metal frame that holds printed circuit cards.

CMOS (Complementary Metal Oxide Semiconductor): A technique of arranging transistors which uses very low power.

D

disk access LED: The LED located on the front control panel that indicates when the hard disk drive is active.

E

Electrostatic Discharge (ESD): Stationary electrical charges in which no current flows. Many components on your SBC and in the enclosure are sensitive to damage caused by ESD. ESD can be prevented by wearing a wrist strap attached to a ground post on a static mat.

EMI (ElectroMagnetic Interference): Noise generated by the switching action of the power supply and other system components. Conducted EMI is radiation reflected back into the power line,

Appendix 2 Glossary of Terms

which is normally controlled with a line filter. Radiated EMI is that portion that would radiate into free space, but is suppressed by enclosing a power supply's circuitry in a metal case. The FCC governs conducted and radiated emission levels in the U.S.

expansion card: A printed circuit board that plugs into an expansion slot.

F

front control panel: The small panel on the front of the computer that contains the power switch, reset switch, Power ON LED, the disk access LED, and the keyboard connector.

H

hold-down bar: Located directly beneath the top cover, the hold-down bar is mounted over the expansion slots on the backplane. Its purpose is to hold the expansion cards securely in their slots.

I

IDE (Integrated Drive Electronics): A standard of signalling and communicating with a device.

K

keyboard connector: The five-pin connector located on the front control panel.

Kilobyte (KB): 1,024 bytes.

P

parallel port: I/O connector used to hook up a printer or other parallel interface device. The parallel port is usually a 25-pin female DB25 connector.

Appendix 2 Glossary of Terms

port: Ports are used to connect peripheral devices such as external drives and printers to your computer.

power good: Signal used to prevent the computer from starting until the power has stabilized. The power good line switches from 0 to +5 volts within one tenth to one half second after the power supply reaches normal voltage levels. Whenever low input voltage causes the output voltage to fall below operating levels, the power good signal goes back to zero.

Power ON LED: The LED located on the front control panel that indicates that power is present in the computer.

power switch: Located on the front control panel, the power switch turns power ON to the computer.

power supply: Electrical system that converts AC current from the wall outlet into the DC currents required by the computer circuitry. In a personal computer, +5, -5, +12 and -12 voltages are generated. The 5 volts are used for the electronic circuitry, and the 12 volts are required for the drives.

R

Real-time clock (RTC): A periodic interrupt used to derive local time.

reset switch: Computer button or key that reboots the computer. All current activities are stopped cold and any data in memory is lost.

retaining bracket: The bracket on the back of the chassis that holds connectors from the board, usually a DB9 for serial port, a DB25 for parallel port, and mini-DIN connectors for keyboard and mouse.

S

serial port: A two-channel port, one channel used for "In" transmissions and one for "Out" transmissions.

Appendix 2 Glossary of Terms

SCSI (Small Computer System Interface): A high speed, general purpose interface to storage devices.

Appendix 3 Illustrations

This appendix provides illustrations of the 3800 system enclosure configurations, the 8-slot ISA backplane, the 8-slot PCI/ISA backplane, and the system interconnect diagram.

Configurations

The 3800 system enclosure is available in a tower configuration.

8-Slot ISA Passive Backplane

A fold-out illustration of the 8-slot backplane shows all the connectors. J1 through J8 are the expansion card slots. J11 through J14 are the backplane power connectors.

8-slot PCI/ISA Dual-Bus Passive Backplane

A fold-out illustration of the 8-slot dual-bus passive backplane shows all the connectors. J1, J2, J3, and J5 are ISA connectors. J4/J10 is for the CPU board. J8 and J9 are PCI expansion slots. And J6/J7 is a shared ISA and PCI slot, only one of which can be used at a time.

3800 System Enclosure Interconnect Diagram

A fold-out illustration shows the interconnection of the components of the 3800 system enclosure, including pin-out descriptions of the connectors.

Appendix 3 Illustrations

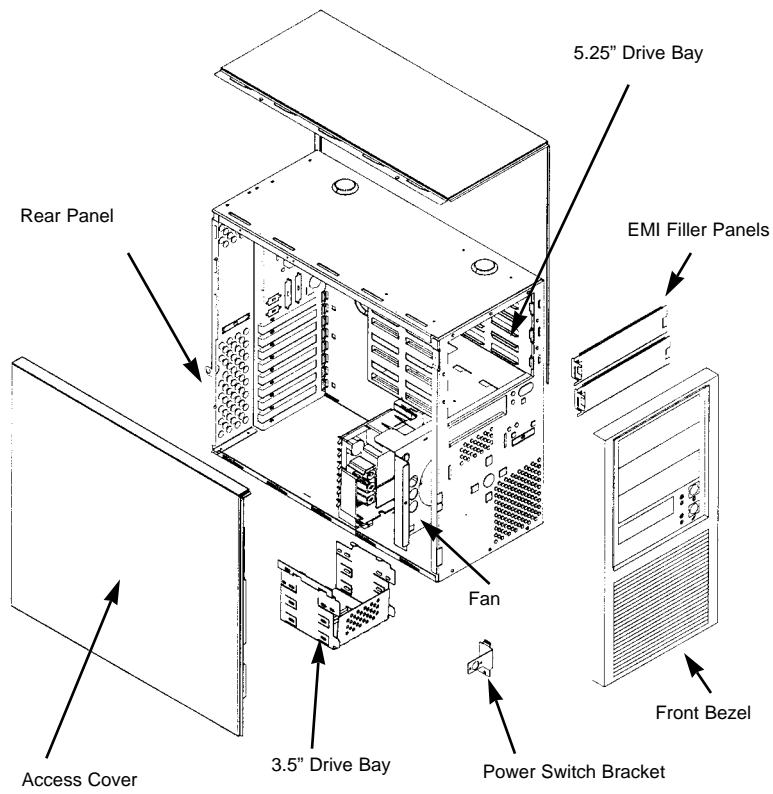

3800 System Enclosure

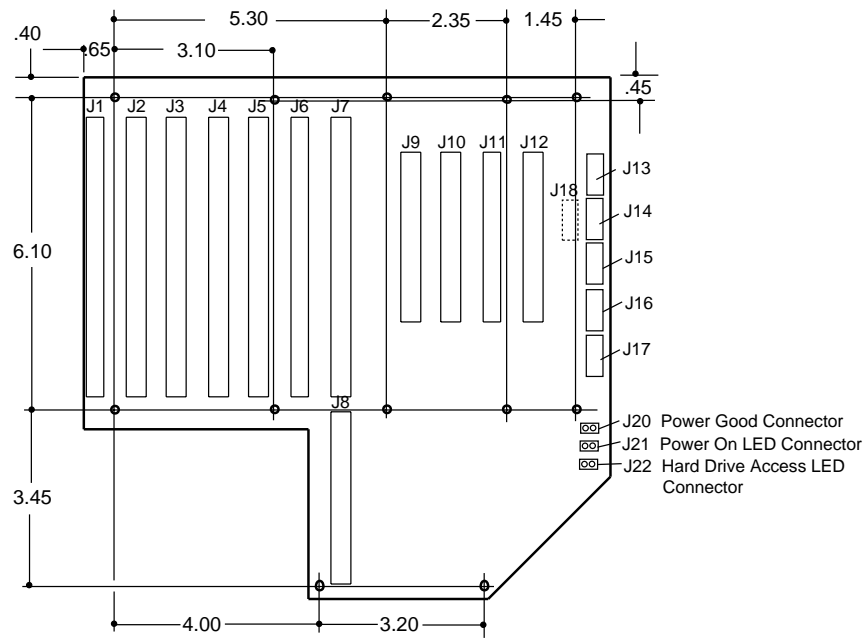

PCI/ISA 11-Slot Passive Backplane

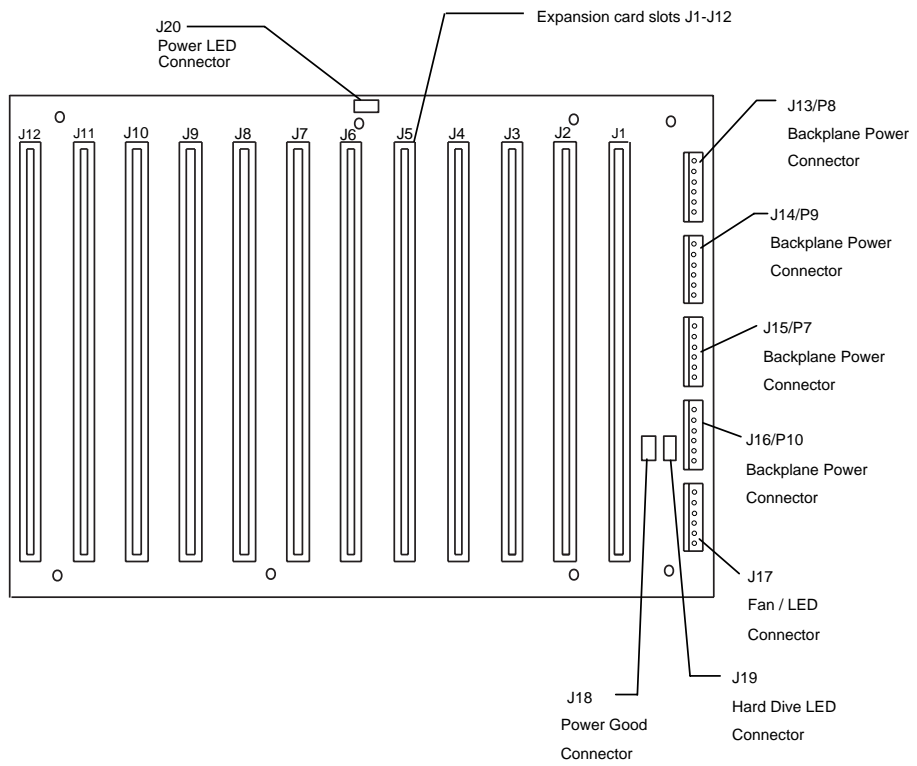

ISA 12-Slot Passive Backplane

This chassis has been tested and is compliant with Low Voltage Directive 73123/EEC. If equipment other than I-Bus manufacture is installed in the chassis, retesting may be required to assure compliance.

This device complies with Part 15 of the FCC Rules. Operation is subject to the following two conditions: (1) this device may not cause harmful interference, and (2) this device must accept any interference received including interference that may cause undesired operation.*

WARNING: This equipment has been tested and found to comply with the limits for a Class “A” digital device, pursuant to part 15 of the FCC Rules. These limits are designed to provide reasonable protection against harmful interference when the equipment is operated in a commercial environment. This equipment generates, uses and can radiate radio frequency energy and, if not installed and used in accordance with the instruction manual, may cause interference to radio communications. Operation of this equipment in a residential area is likely to cause harmful interference in which case users will be required to correct the interference at their own expense.

Changes or modifications not expressly approved by the party responsible for compliance could void the user’s authority to operate the equipment.

NOTE: This product was FCC verified under test conditions that included the use of shielded I/O cables and connectors between system components. To be in compliance with FCC regulations, the user must use shielded cables and connectors and install them properly.

*FCC compliance applies only if the following conditions are met: (1) the CPU board enclosed in this package or accompanying this manual is installed in an I-Bus chassis, or (2) the chassis enclosed in this package or accompanying this manual contains an I-Bus enclosure.